

**Detail Z**  
(Typical detail for interface between fuselage and wing)

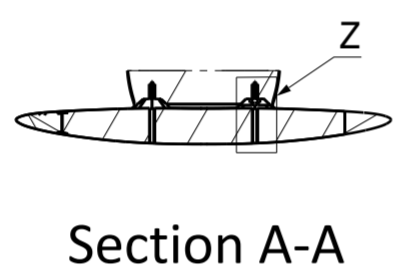

**Section A-A**

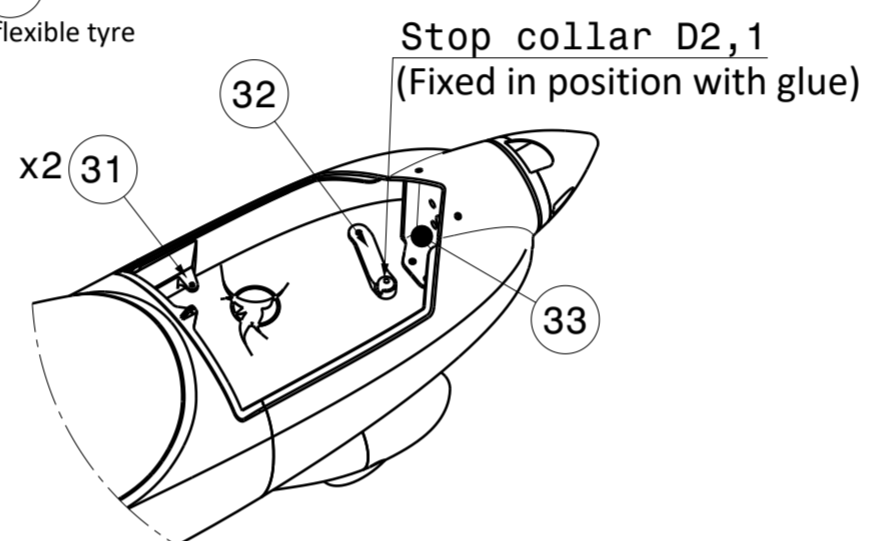

**Section B-B**  
(Concept valid also for join between WingC and Wing1R)

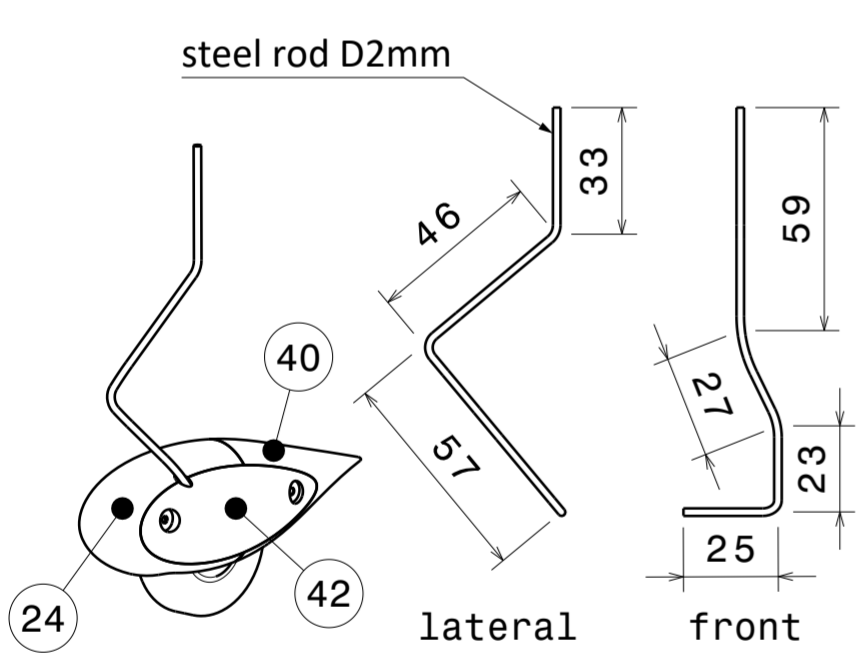

**NOSE LANDING GEAR**

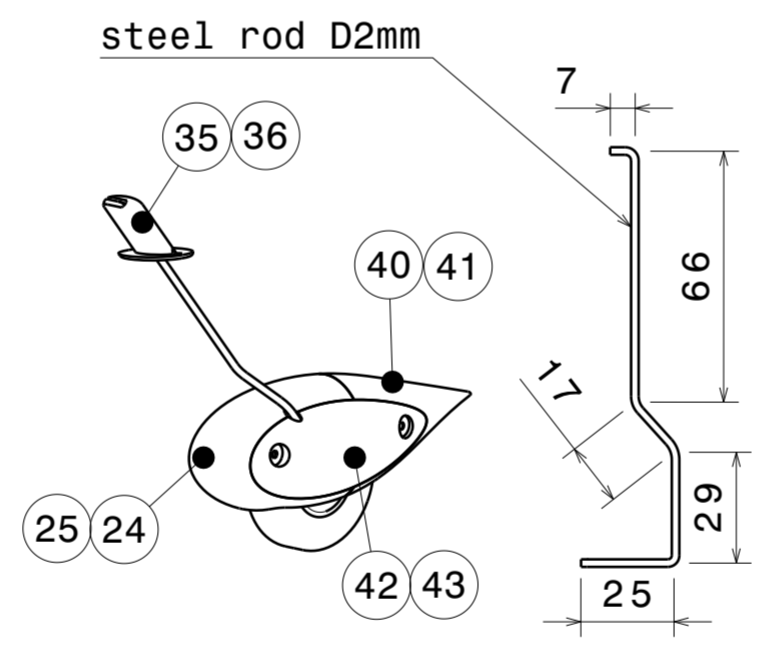

**MAIN LANDING GEAR**

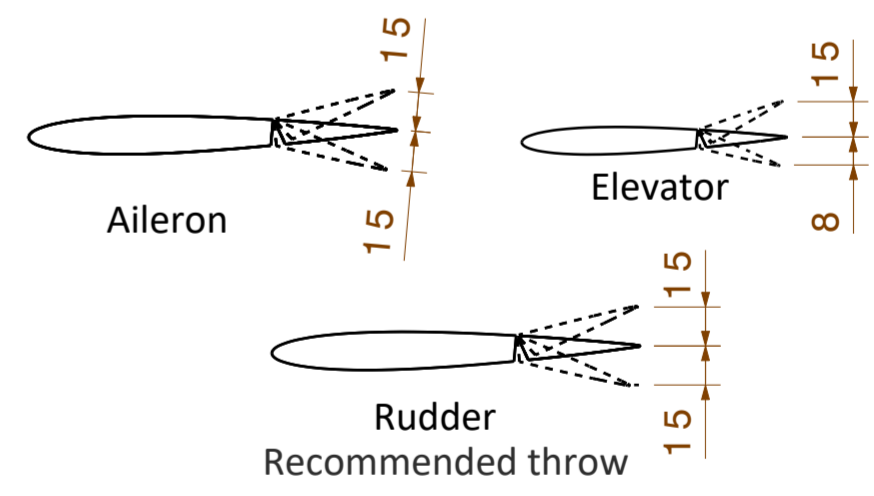

**Recommended throw**

ITEM	NAME	CATEGORY
1	Spinner1	C
2	Spinner2	C
3	Fus1	A / A-LW
4	Canopy1	A / A-LW
5	Fus2	A / A-LW
6	Fus3	A / A-LW
7	Fus4	A / A-LW
8	Fus5	A / A-LW
9	VTP	A / A-LW
10	Rudder	A / A-LW
11	WingC	A / A-LW
12	Wing1L	A / A-LW
13	Wing1R	A / A-LW
14	Wing2L	A / A-LW
15	Wing2R	A / A-LW
16	Wing3L	A / A-LW
17	Wing3R	A / A-LW
18	AileronL	A / A-LW
19	AileronR	A / A-LW
20	HTP_1	A / A-LW
21	HTP_2	A / A-LW
22	Elev	A / A-LW
23	Elev_horn	C / C-LW
24	Wheel_fairing_1L	C / C-LW
25	Wheel_fairing_1R	C / C-LW
26	Wheel	C / C-LW
27	Rim	C / C-LW
28	Tyre	C
29	NLG_stopper	C
30	Anchor_nut_M3_wing	C
31	Servo_holder_fus	C
32	NLG_horn	C
33	Motor mount	C
34	Guide	C
35	MLG_root_L	C
36	MLG_root_R	C
37	Servo_holder_Wing	C
38	Cover_horn	C
39	Root_LE	C / C-LW
40	Wheel_fairing_2L	C / C-LW
41	Wheel_fairing_2R	C / C-LW
42	Wheel_fairing_3L	C / C-LW
43	Wheel_fairing_3R	C / C-LW

- 11 Add 2 top layers
- 10 Add 8 bottom layers
- 9 Add 2 bottom layers (parts marked with this flag note)
- 8 Print "tyre" with flexible material.
- 7 If you can not use fan, ensure enough time between layers to cool down material.
- 6 If you can not heat the bed use Spray Adhesive
- 5 If your motor reach temperatures over 50 °C use ABS or PETG for "Motor\_mount"  
4-Center of gravity marking under the wing.  
It is recommended to set the C.G. 5 mm forward for the maiden flight  
3-Do not print LW-PLA parts at the same time with others to avoid stringing in the outer surface.  
2-Stringing can not be eliminated for LW-PLA material.

1- Red parameters are mandatory to ensure airplane functionality, assembly or weight target.

PRINTING PARAMETER	CATEGORY			
	A-LW	A	C-LW	C
Layer height (mm)	0.25	0,2	0,15	0,13
Bottom layers	0	0	4	4
Top layers	0	0	6	6
Wall lines / perimeter	1	1	2	2
Nozzle diameter (mm)	0,4	0,4	0,4	0,4
Material	LW-PLA	PLA/PETG	LW-PLA	PLA/PETG FLEX/ABS
Infill density (%)	0	0	10	10
Printing temp (°C)	235	220	235	205 to 240
Bed temp (°C)	60	60	60	60
Flow (%)	53	100	53	100
Retraction (mm)	0,5 to 3	0,5 to 3	0,5 to 3	3
Retraction extra prime amount (mm)	0 to 0,7	0 to 0,7	0	0
Speed (mm/s)	55	50	35	25 to 50
Fan	YES	YES	YES	YES
Brim (mm)	3 to 5	3 to 5	0 to 3	0 to 3
Minimun layer time (s)	5	5	5	5
Support	NO	NO	NO	NO